

020-0870
Power Locking Pull Handle
With Capacitive Sensor -
PKE



TriMark's new 020-0870 e-LOCK Pull Handle for off-road applications, allows use with TriMark's Gen 3 e-ASK Passive Keyless Entry System featuring integrated capacitive sensor, PKE circuit board and power lock/unlocking motor drive. Based on the proven 020-0850, this robust pull handle brings the latest automotive functionality and convenience to your cab enclosures.

DESIGNED FOR:

- Medium to heavy-duty agricultural and construction personnel doors
- Off-highway vehicle applications that require a direct release surface mounted exterior pull handle and "state of the art" Passive Keyless Entry

Global Locations:

TriMark Corporation
500 Bailey Avenue
P.O. Box 350
New Hampton, Iowa 50659
United States
Tel: 641-394-3188
Fax: 641-394-2392
1-800-447-0343
www.trimarkcorp.com

TriMark Europe
Cedar Court
Walker road
Bardon Hill
Coalville LE67 1TU
United Kingdom
Tel: +44(0)1530 512460
Fax: +44(0)1530 512461
www.trimarkeu.com

TriMark (Xuzhou)
Building A5 Jingwu Road
Xuzhou Economic
Development Zone
Xuzhou, Jiangsu
221004 PR China
Tel: +86 516 8773 0018
Fax: +86 516 8773 0058
www.trimarkcn.com



TriMark. Interactive. Product. Selector



FEATURES/BENEFITS:

- Extends the product range of TriMark 020-0850 e-LOCK Pull Handle with an Integrated Capacitive Sensor and Passive Keyless Entry PCB board into the base. This minimizes footprint profile of handle to maximize visibility to the user.
- Passive Keyless Entry (PKE) provides for “hands free” unlocking
 - When the users hand enters the field under the handle portion, the system wakes up
 - This activity energizes the exterior antenna. FOBs in range will respond with their serial numbers contained in a data packet sent via 433 MHz
 - If the FOBs respond with serial numbers that match an authorized list, the control module will pulse the unlock motor for ½ second to unlock

- Powerlock/unlock motor integrated into handle to reduce assembly and space needs of vehicle
- Maintains lock cylinder for mechanical override in case of power disruption
 - TriMark KeyOne™ Plus for “One Key — One Vehicle” convenience
- Readily adaptable to a variety of door thickness with adjustable connecting linkage assembly
- PTC overload protects motor against excessive heating
- Best in class features, flexibility and performance all in one package allowing fewer system configurations

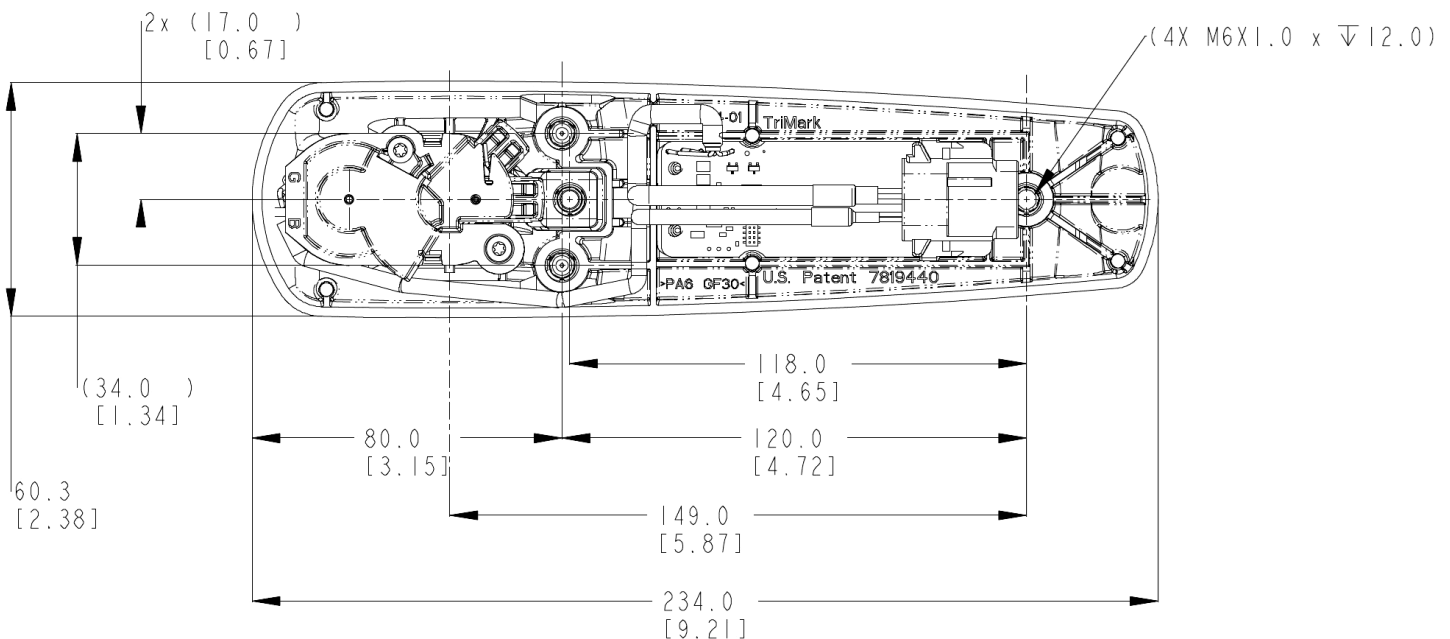
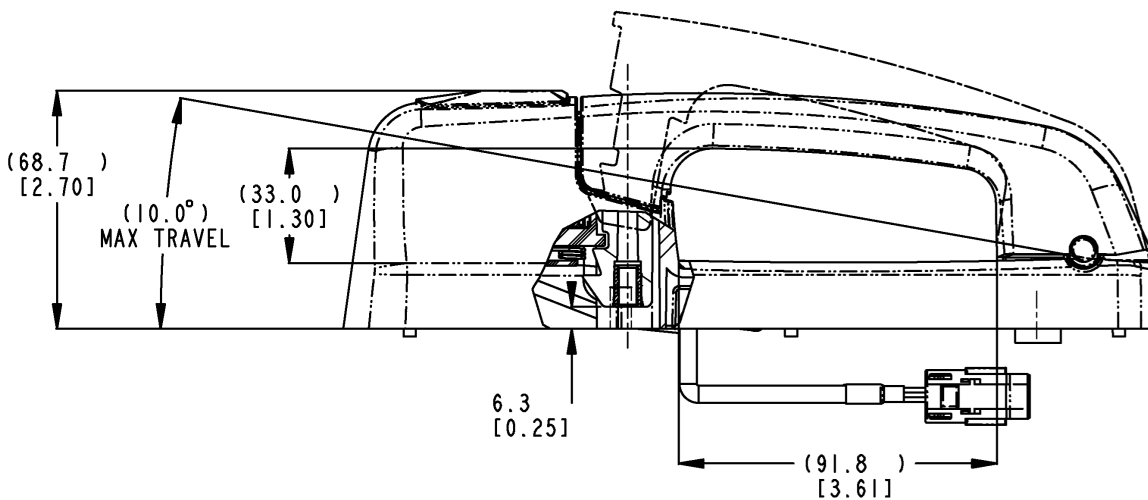

AVAILABLE:

- With perimeter gasket and spacers to facilitate mounting and provide resistance to water and dirt infiltration
- Non-power locking version and non-capacitive sense version
- Standard Deutsch sealed connector — 8 pin socket plug. (Connector customizations are available)
- In 12V and 24V versions

MATERIAL:

- Handle and base: Glass reinforced nylon
- Threaded inserts: Brass
- Potted (polyurethane resin) PCB board ensures environmental protection and durability

INSTALLATION:

- Same mounting pattern as 020-0800 and 020-0850 Pull Handles — mounts against glass with only two holes or steel with conventional mounting
- Installed with (3) M6 x 1.0 bolts (not included)
- Recommended mounting fastener torque to be 5.6-6.7 N-m (50-59 lbf-in)

USE WITH:

- TriMark 500-1300 e-ASK PKE Unsealed System
- TriMark 500-1350 e-ASK PKE Sealed System

U.S. Patent No. 7,819,440 / 10,385,594

CAUTION: Product does not meet the locking requirements for FMVSS 206 (ECE R11).

Individual part dimensions are for reference only. Refer to individual part drawings for complete dimensions, specifications, and installation procedures. Engineering assistance and application drawings are available.

For more information visit
www.trimarkcorp.com

**RECOMMENDED GLASS MOUNTING
DOOR CUTOUT DETAIL**